

PM



MATERIALS

Housing:
Anodized aluminium alloy

Bypass valve:
Steel

Seals:
NBR Nitrile
(FKM - on request fluoroelastomer)

Indicator housing:
Brass

PRESSURE (ISO 10771-1:2002)

Max. working: 21 MPa (210 bar)

Test: 33 MPa (330 bar)

Bursting: 66 MPa (660 bar)

Collapse, differential
for the filter element (ISO 2941):
2,1 MPa (21 bar)

BYPASS VALVE

Setting:
600 kPa (6 bar) \pm 10%

WORKING TEMPERATURE

From -25° to +110° C

COMPATIBILITY (ISO 2943:1999)

Full with fluids: HH-HL-HM-HV-HTG
(according to ISO 6743/4)
For fluids different than the above
mentioned, please contact our Sales
Department.

APPLICATION EXAMPLE

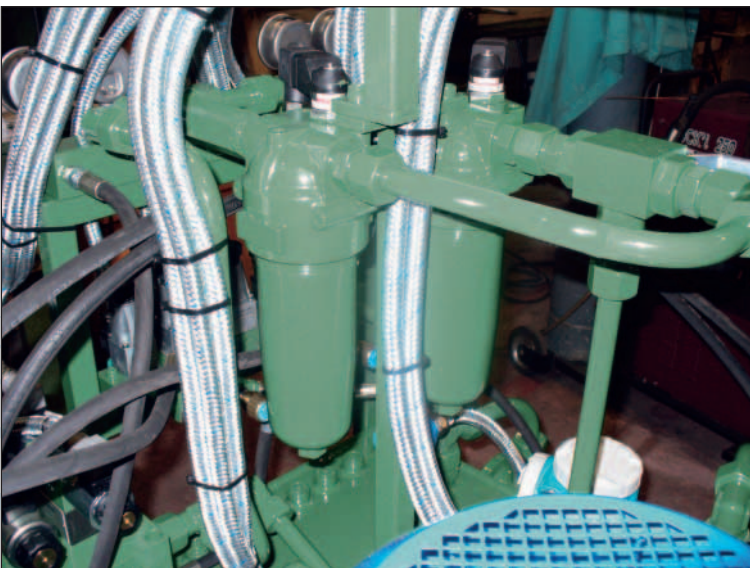

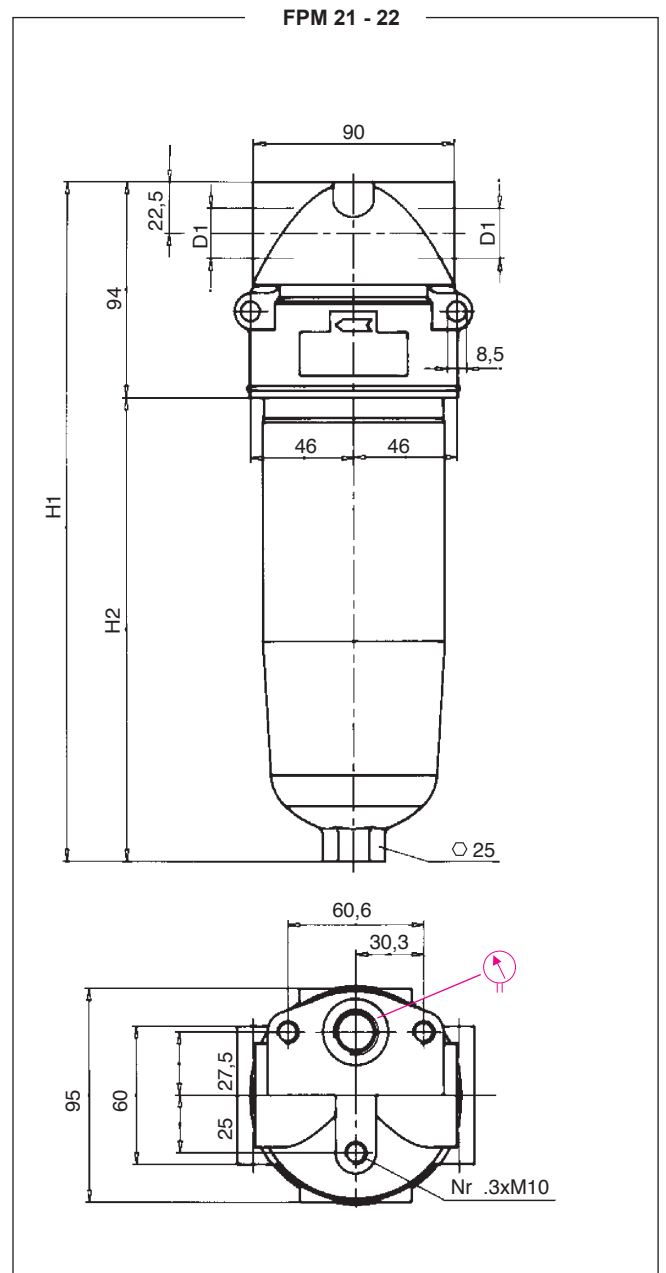
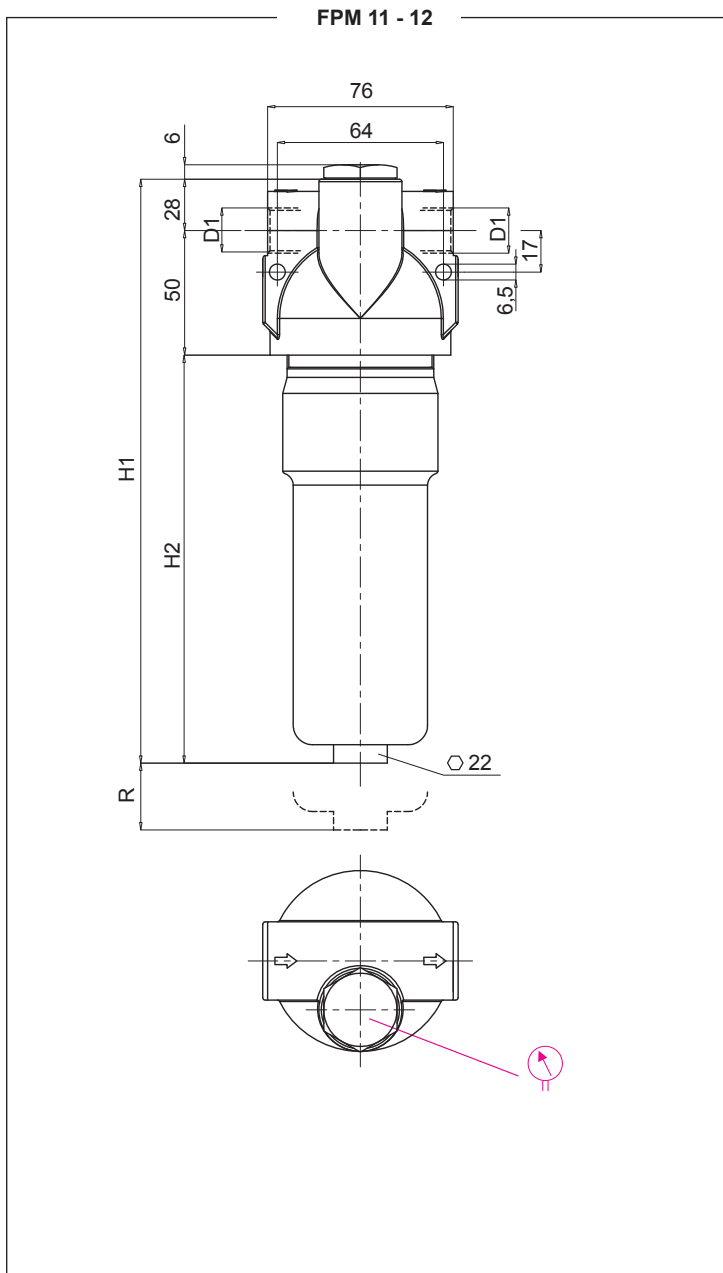

FILTER HOUSING

	D1	H1	H2	R	kg
FPM11	1/2"	157	79	60	0,65
FPM12	1/2"	244	166	60	0,85
FPM21	1/2"-3/4"-1"	205	111	100	1,5
FPM22	1/2"-3/4"-1"	298	197	100	2,0

		TYPE						
		F = FILTER COMPLETE	F	F	F	F		
		B = FILTER HOUSING	B	B	B	B	ELEMENT	E
P	M	FAMILY, SIZE & LENGTH						
			11	12			FAMILY SIZE & LENGTH	P A
					21	22	P B	
		PORT TYPE						
		B = BSP thread	B	B	B	B		
		N = NPT thread	N	N	N	N		
		S = SAE thread	S	S	S	S		
		PORT SIZE						
		04 = 1/2"	04	04	04	04		
		06 = 3/4"	06	06	06	06		
		08 = 1"	08	08	08	08		
		BYPASS VALVE						
		W = without	W	W	W	W		
		C = 600 kPa (6 bar)	C	C	C	C		
		SEALS					SEALS	
		N = NBR Nitrile	N	N	N	N	N = NBR	
		F = FKM Fluoroelastomer	F	F	F	F	F = FKM	
		FILTER MEDIA					FILTER MEDIA	
		FA = fiber 5 $\mu\text{m}_{(e)}$ $\beta > 1.000$	FA	FA	FA	FA	FA = fiber 5 $\mu\text{m}_{(e)}$	
		FB = fiber 7 $\mu\text{m}_{(e)}$ $\beta > 1.000$	FB	FB	FB	FB	FB = fiber 7 $\mu\text{m}_{(e)}$	
		FC = fiber 12 $\mu\text{m}_{(e)}$ $\beta > 1.000$	FC	FC	FC	FC	FC = fiber 12 $\mu\text{m}_{(e)}$	
		FD = fiber 21 $\mu\text{m}_{(e)}$ $\beta > 1.000$	FD	FD	FD	FD	FD = fiber 21 $\mu\text{m}_{(e)}$	
		CC = cellulose 10 μm $\beta > 2$	CC	CC	CC	CC	CC = cellulose 10 μm	
		CLOGGING INDICATOR						
		03 = port, plugged	03	03	03	03	When the filter is ordered with FKM seals, the first digit of the indicator code is a letter (please see page 182 - 183).	
		5E = visual differential 500 kPa (5 bar)	5E	5E	5E	5E		
		6E = electrical differential 500 kPa (5 bar)	6E	6E	6E	6E		
		7E = indicator 6E with LED	7E	7E	7E	7E		
		T2 = elect. diff. 500 kPa (5 bar) with thermostat 30°C	T2	T2	T2	T2	N.B. Indicator series 72 only on request	
X	X	ACCESSORIES						
		XX = no accessory available	XX	XX	XX	XX		

FILTER ELEMENT

	A	B	C	kg	Area (cm ²)	
					Media F+	Media C+
EPA11	22	42	91	0,15	295	295
EPA12	22	42	179	0,25	600	600
EPB21	23,5	52	115	0,25	975	780
EPB22	23,5	52	210	0,35	1.830	1.465

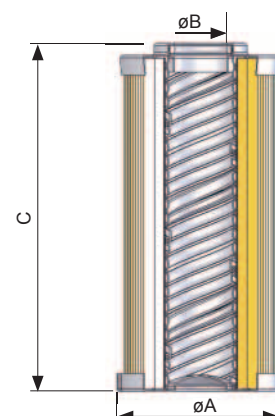

FLUID SPEED

(when selecting the filter size, we suggest to consider also the max recommended fluid speed (in pressure lines normally $5 < v < 10$ m/s)

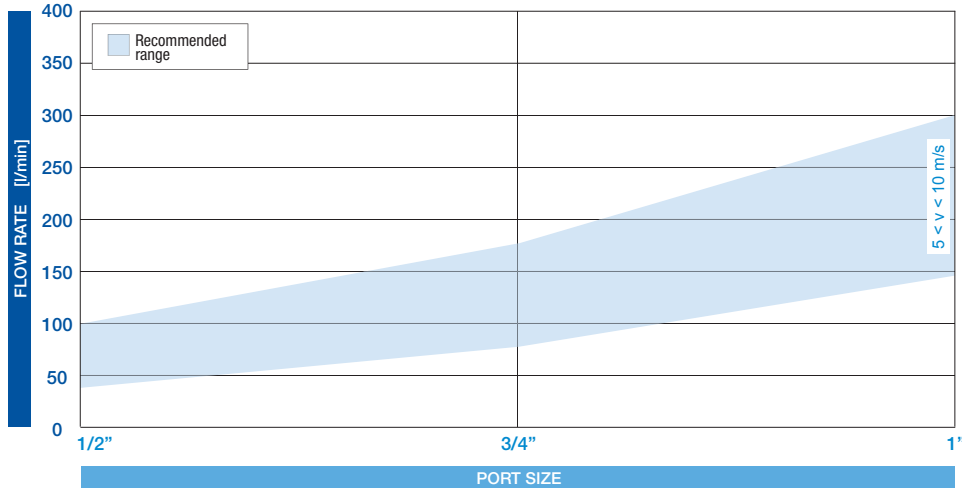

PRESSURE DROP CURVES (Δp)

The "Assembly Pressure Drop (Δp)" is obtained by adding the pressure drop values of the Filter Housing and of the Clean Filter Element corresponding to the considered Flow Rate and it must be lower than 120 kPa (1,2 bar).

FILTER HOUSING PRESSURE DROP (mainly depending on the port size)

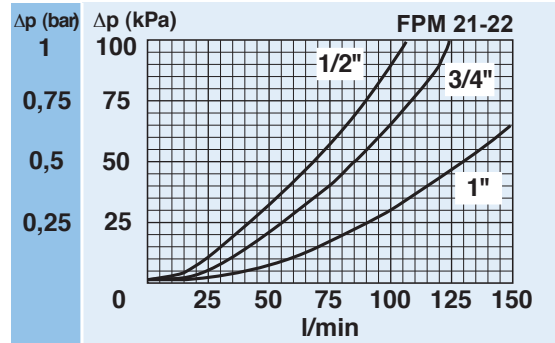
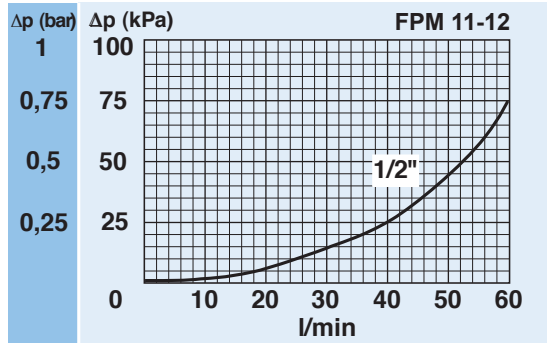

**CLEAN FILTER ELEMENT PRESSURE DROP
WITH F+ AND C+ MEDIA**

(depending both on the internal diameter of the element and on the filter media)

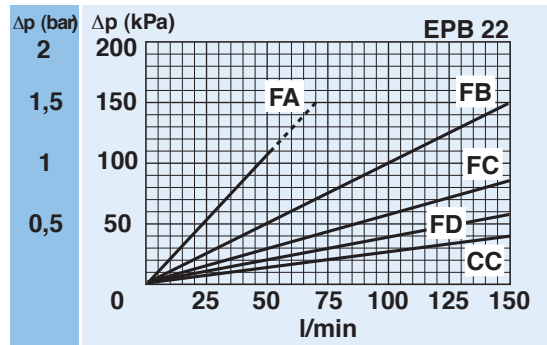
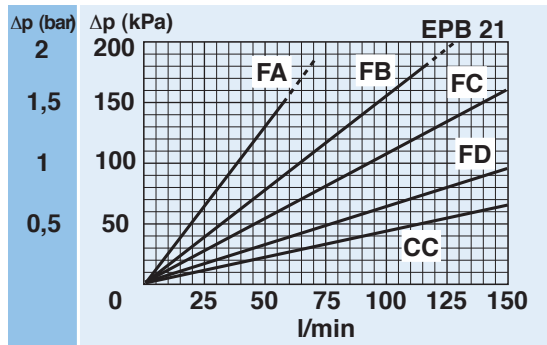
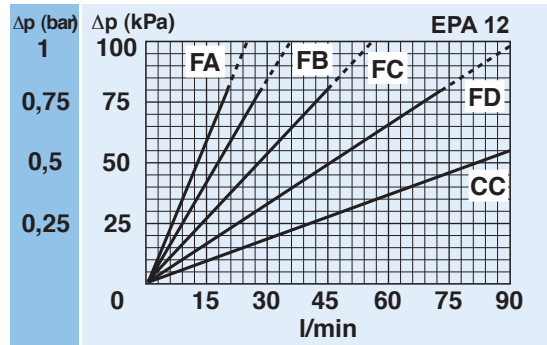
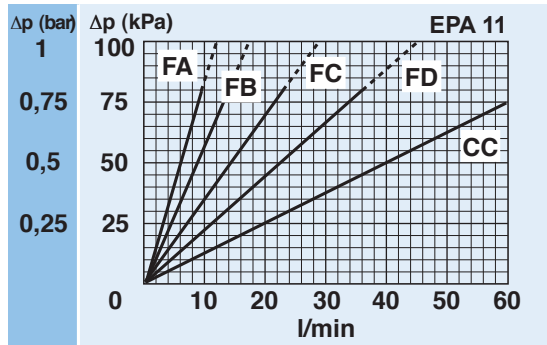

BYPASS VALVE PRESSURE DROP

When selecting the filter size, these curves must be taken into account if it is foreseen that any flow peak is to be absorbed by the bypass valve, it also must be of proper configuration to avoid pressure peaks. The valve pressure drop is directly proportional to fluid specific gravity.

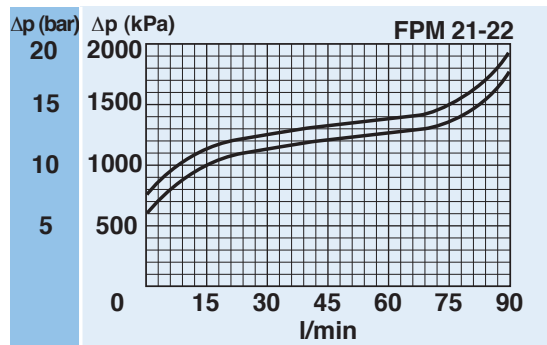
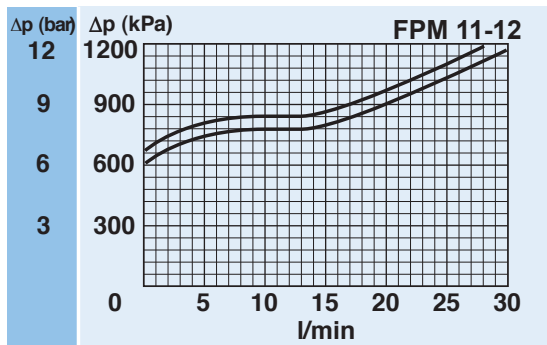

N.B. All the curves have been obtained with mineral oil having a kinematic viscosity 30 cSt and specific gravity 0,9 kg/dm³; for fluids with different features, please consider the factors described in the first part of this catalogue. All the curves are obtained from test done at the UFI HYDRAULIC DIVISION Laboratory, according to the specification ISO 3968:2005. In case of discrepancy, please check the contamination level, viscosity and features of the fluid in use.

CLOGGING INDICATOR

A visual or visual-electrical differential indicator is available as an option and allows monitoring of the element conditions, giving an exact indication of the right time to replace the element.

FILTER HOUSING

Head and bowl are made by high performance aluminium alloy ensuring the best fatigue resistance.

FILTER ELEMENT

The filter element is manufactured with filter medias selected in the UFI laboratory and mechanically supported to maintain the highest performance even at high differential pressures.

SEAL GUARANTEED

A perfect O-ring seal is always ensured as it is not dependent on the tightening torque applied to the bowl.

EASY MAINTENANCE

The hexagon end of the bowl allows for easy maintenance by using a simple hexagon wrench.

CLOGGING INDICATOR

For further technical informations and other options see page 182-183.



Differential

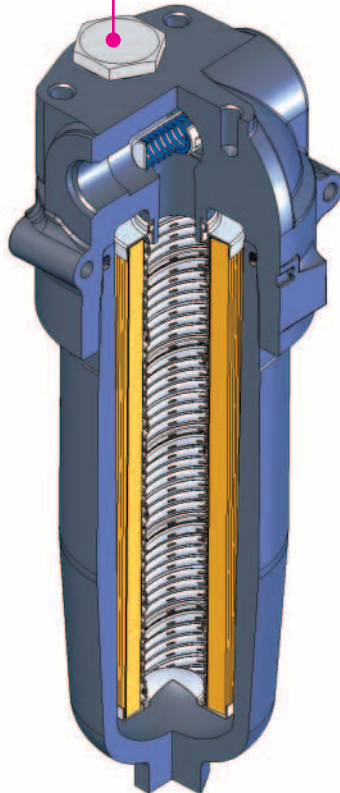

SPARE SEAL KIT

	NBR	FKM
FPM11	521.0001.2	521.0062.2
FPM12	521.0001.2	521.0062.2
FPM21	521.0011.2	521.0010.2
FPM22	521.0011.2	521.0010.2

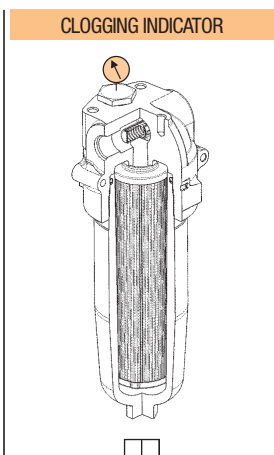
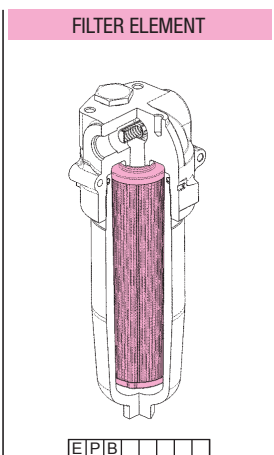
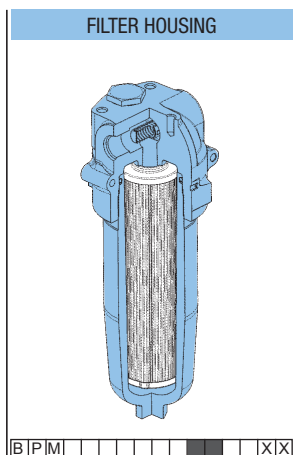

SPARE PARTS ELEMENTS
(For filling up see table
"Ordering and option chart")

