

RD



MATERIALS

Cover & housing:
Anodized aluminium alloy

For 61&62 only:
Cover: anodized aluminium alloy
Housing: steel

Bypass valve:
Polyamide

Seals:
NBR Nitrile
(FKM - on request fluoroelastomer)

Indicator housing:
Brass

PRESSURE (ISO 10771-1:2002)

Max working:
2 MPa (20 bar)

Test:
3 MPa (30 bar)

Bursting:
6 MPa (60 bar)

Collapse, differential
for the filter element (ISO 2941):
1 MPa (10 bar)

BYPASS VALVE

Setting:
300 kPa (3 bar) $\pm 10\%$

WORKING TEMPERATURE

From -25° to $+110^{\circ}$ C

COMPATIBILITY (ISO 2943:1999)

Full with fluids: HH-HL-HM-HV-HTG
(according to ISO 6743/4)
For fluids different than the above mentioned,
please contact our Sales Department.

APPLICATION EXAMPLE



FRD 11-21-31-41-51

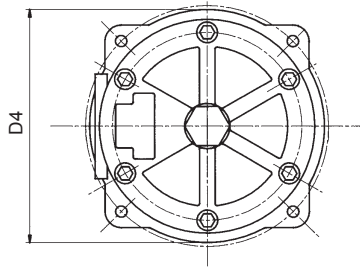
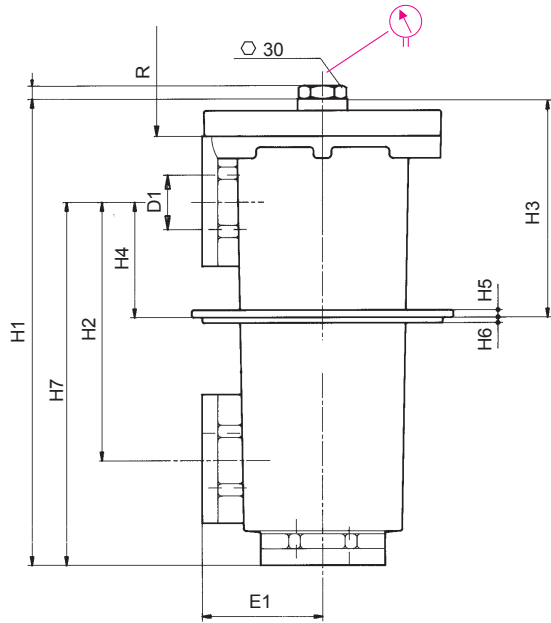

Tank mounting pattern

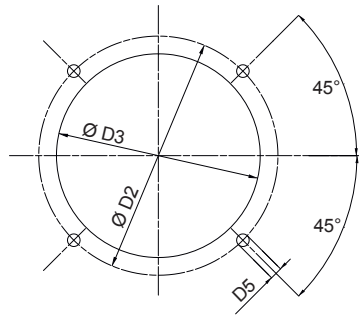

FRD 61- 62

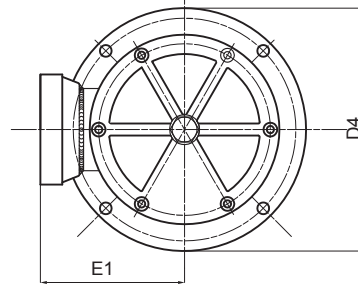
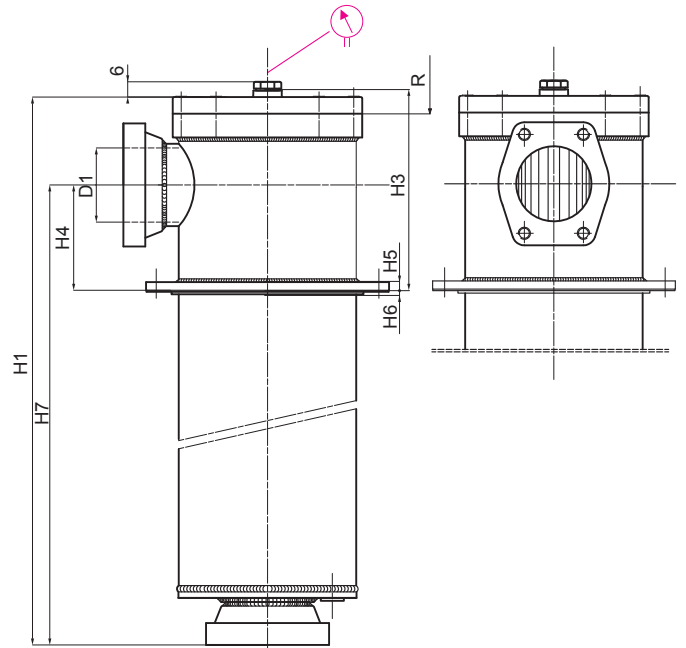

Tank mounting pattern

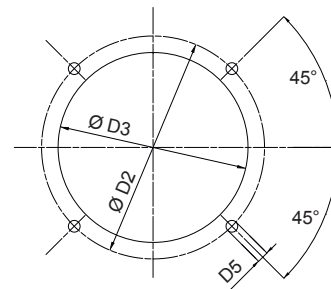

(* Adjustable for RD62 only - loose flange (to be welded))

FILTER HOUSING

	D1	D2	D3	D4	D5	E1	H1	H2	H3	H4	H5	H6	H7	R	kg
FRD11	1/2"	95	85	90	M5	43	160	62,5	96	31,5	4	3	96	105	1,3
FRD21	3/4"	138	123	128	M6	57	191	105	100	52	6	3	145	110	2,6
FRD31	1"	154	137	147	M6	67	250	140	117	63	8	4	197	155	3,7
FRD41	1" 1/2	180	164	174	M8	82	343	177	155	82	8	4	269	240	6,5
FRD51	2" 1/2	275	239	254	M10	117,5	420	218	192	91	10	8	320	275	14,2
FRD61	3" 1/2	275	239	300	M12	178	673	-	248	130	10	5	-	525	49,0
FRD62	4"	275	239	300	M12	178	1.108	-	423*	255	10	5	950	1.020	70,0

TYPE											
F = FILTER COMPLETE		F	F	F	F	F	F	F	ELEMENT		E
B = FILTER HOUSING		B	B	B	B	B	B	B	FAMILY SIZE & LENGTH		R D
R	D										
FAMILY NOMINAL SIZE & LENGTH		11	21	31	41	51	61	62			
PORT TYPE											
B = BSP thread		B	B	B	B	B	-	-			
N = NPT thread		N	N	N	N	N	-	-			
S = SAE thread		S	S	S	S	S	-	-			
F = SAE flange 3000 psi, metric screws		-	-	F	F	F	F	F			
PORT SIZE											
04 = 1/2"		04	-	-	-	-	-	-			
06 = 3/4"		-	06	-	-	-	-	-			
08 = 1"		-	-	08	-	-	-	-			
12 = 1" 1/2		-	-	-	12	-	-	-			
20 = 2" 1/2		-	-	-	-	20	-	-			
28 = 3" 1/2		-	-	-	-	-	28	-			
32 = 4"		-	-	-	-	-	-	32			
BYPASS VALVE											
W = without		W	W	W	W	W	W	W			
D = 300 kPa (3 bar)		D	D	D	D	D	D	D			
SEALS											
N = NBR Nitrile		N	N	N	N	N	N	N	SEALS		N = NBR
F = FKM Fluoroelastomer		F	F	F	F	F	F	F			F = FKM

FILTER MEDIA								FILTER MEDIA				
FA = fiber 5 μm _(c) β>1.000	FA	FA	FA	FA	FA	FA	FA	FA = fiber 5 μm _(c)				
FB = fiber 7 μm _(c) β>1.000	FB	FB	FB	FB	FB	FB	FB	FB = fiber 7 μm _(c)				
FC = fiber 12 μm _(c) β>1.000	FC	FC	FC	FC	FC	FC	FC	FC = fiber 12 μm _(c)				
FD = fiber 21 μm _(c) β>1.000	FD	FD	FD	FD	FD	FD	FD	FD = fiber 21 μm _(c)				
CC = cellulose 10 μm β>2	CC	CC	CC	CC	CC	CC	CC	CC = cellulose 10 μm				
CD = cellulose 25 μm β>2	CD	CD	CD	CD	CD	CD	CD	CD = cellulose 25 μm				
MD = wire mesh 25 μm	MD	MD	MD	MD	MD	MD	MD	MD = wire mesh 25 μm				
ME = wire mesh 60 μm	ME	ME	ME	ME	ME	ME	ME	ME = wire mesh 60 μm				
WR = water removal (*)	-	-	WR	WR	WR	WR	WR	WR = water removal				

(*) water removal media - see "hydro dry" brochure

CLOGGING INDICATOR											
03 = port, plugged	03	03	03	03	03	03	03	When the filter is ordered with FKM seals, the first digit of the indicator code is a letter (please see page 184 - 185).			
5C = visual differential 200 kPa (2 bar)	5C	5C	5C	5C	5C	5C	5C				
6C = electrical differential 200kPa (2 bar)	6C	6C	6C	6C	6C	6C	6C				
7C = indicator 6C with LED	7C	7C	7C	7C	7C	7C	7C				
T1 = elect. diff. 200 kPa (2 bar) with thermostat 30°C	T1	T1	T1	T1	T1	T1	T1	N.B. Indicator series 71 only on request			

ACCESSORIES									
X	X	XX = no accessory available	XX	XX	XX	XX	XX	XX	XX

FILTER ELEMENT

	A	B	C	kg	Area (cm ²)	
					Media F+	Media C+
ERD11	52	28/24	70	0,10	310	380
ERD21	70	34	85	0,20	620	990
ERD31	70	34	130	0,25	1.000	1.600
ERD41	99	51	211	0,70	3.800	4.280
ERD51	130	74	251	1,50	7.930	8.350
ERD61	130	74/85	500	2,00	16.720	17.600
ERD62	143	96,3	896	3,80	40.000	40.000

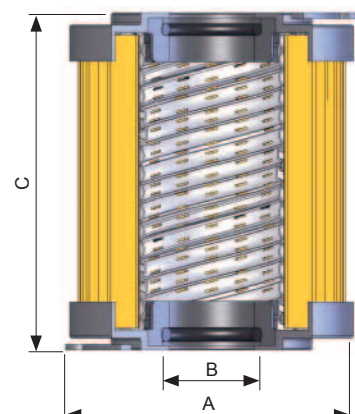

FLUID SPEED

(when selecting the filter size, we suggest to consider also the max recommended fluid speed (in return lines normally $1,5 < v < 4$ m/s)

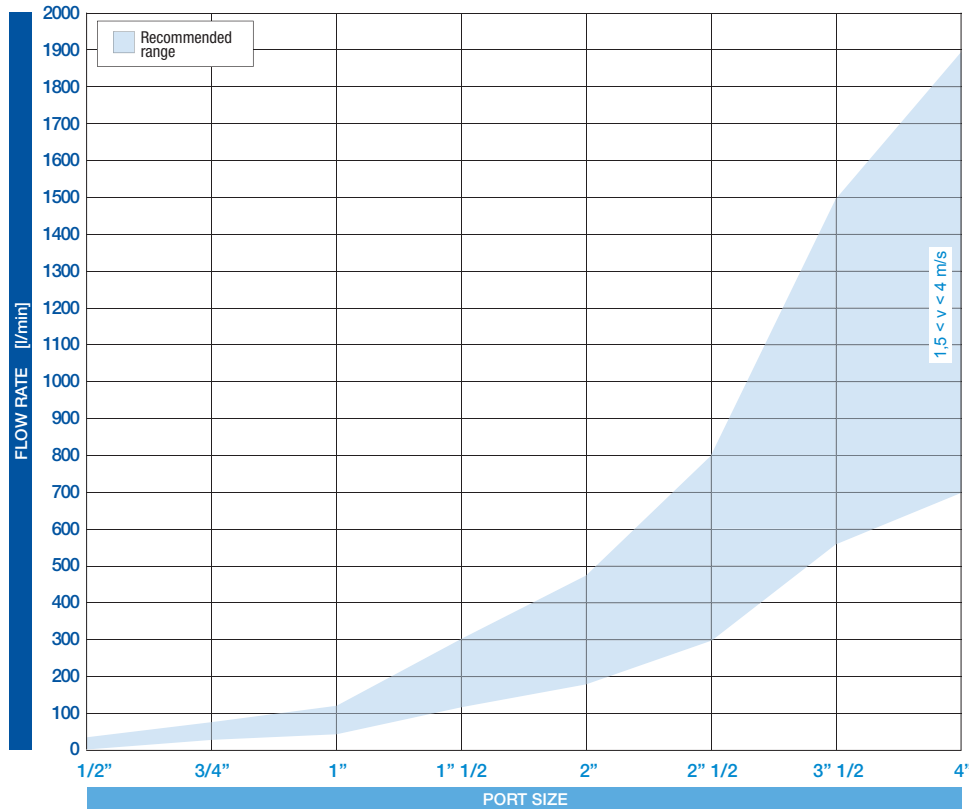

PRESSURE DROP CURVES (Δp)

The "Assembly Pressure Drop (Δp)" is obtained by adding the pressure drop values of the Filter Housing and of the Clean Filter Element corresponding to the considered Flow Rate and it must be lower than 50 kPa (0,5 bar).

FILTER HOUSING PRESSURE DROP
(mainly depending on the port size)

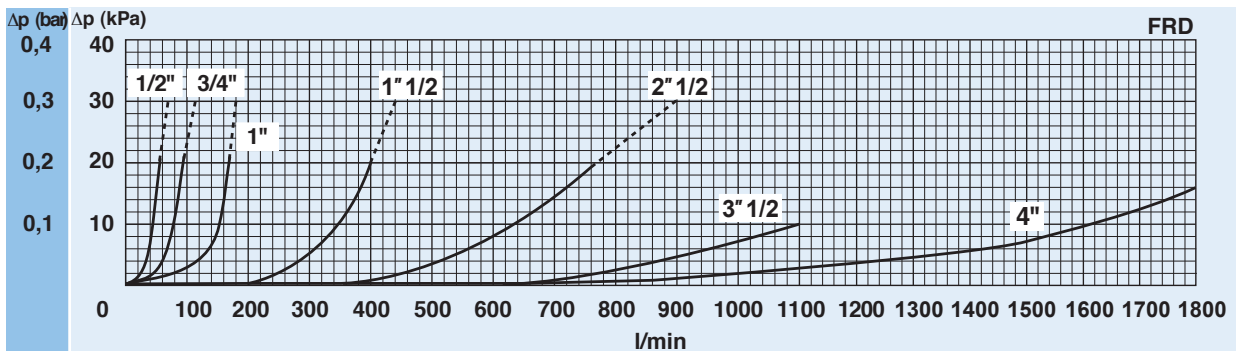

CLEAN FILTER ELEMENT PRESSURE DROP
WITH F+ AND C+ MEDIA

(depending both on the internal diameter of the element and on the filter media)

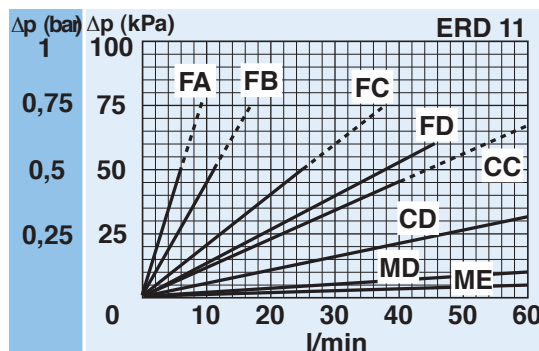

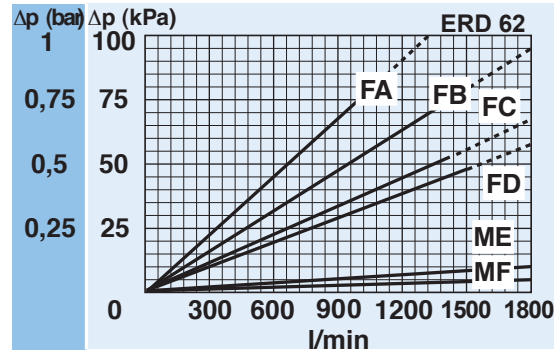
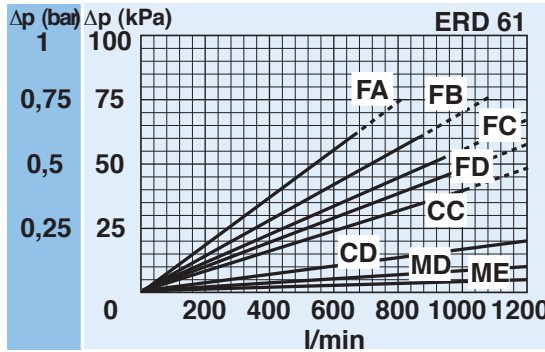
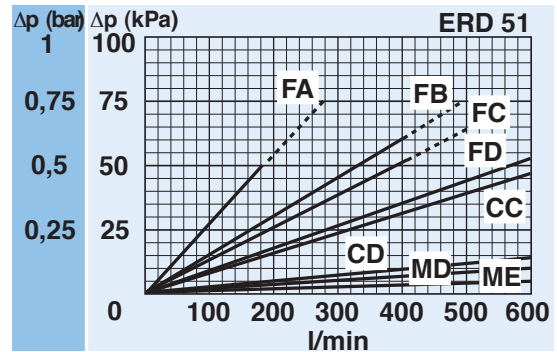
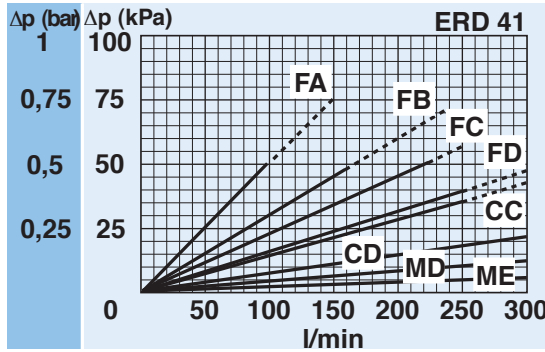
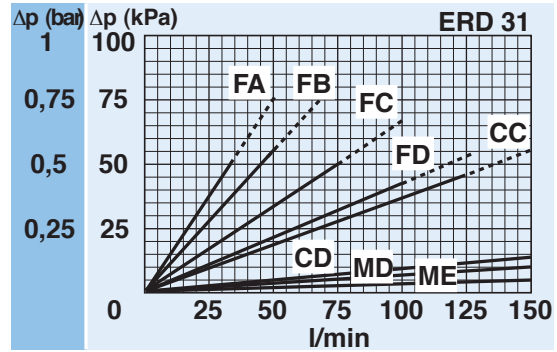
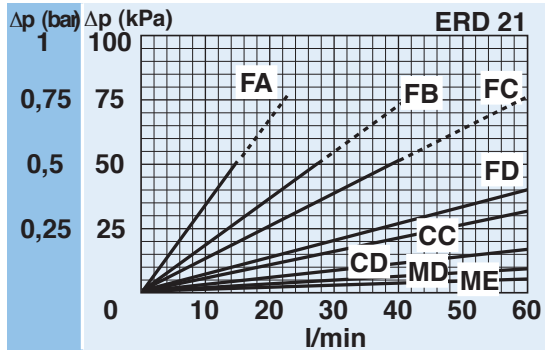

BYPASS VALVE PRESSURE DROP

When selecting the filter size, these curves must be taken into account if it is foreseen that any flow peak is to be absorbed by the bypass valve, it also must be of proper configuration to avoid pressure peaks. The valve pressure drop is directly proportional to fluid specific gravity.

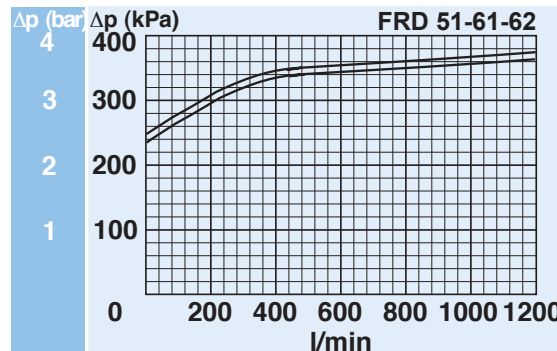
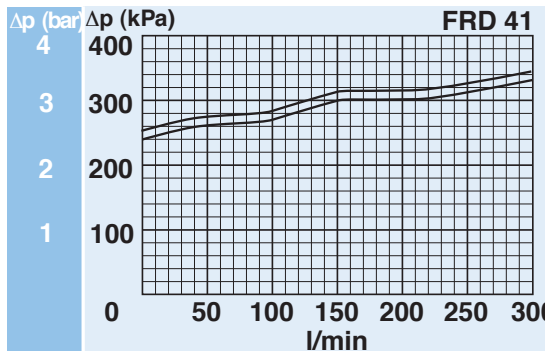
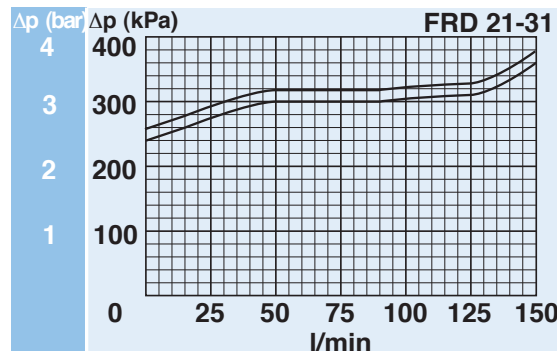
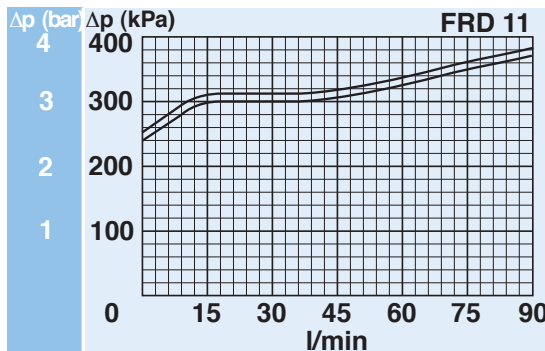

N.B. All the curves have been obtained with mineral oil having a kinematic viscosity 30 cSt and specific gravity 0,9 kg/dm³; for fluids with different features, please consider the factors described in the first part of this catalogue. All the curves are obtained from test done at the UFI HYDRAULIC DIVISION Laboratory, according to the specification ISO 3968:2005. In case of discrepancy, please check the contamination level, viscosity and features of the fluid in use.

CLOGGING INDICATOR

A visual or electrical indicator is available as an option and allows monitoring of the element condition. The port for the indicator is a standard feature.

STRONG CONSTRUCTION

The strong filter housing makes the FRD filters particularly suitable for applications where each component must provide the highest reliability.

FLEXIBILITY OF ASSEMBLING

A second inlet port, supplied plugged, permits you to easily solve special installation needs.

NO LEAKS

The end caps with captive O-ring ensure a perfect sealing between filter element and housing.

CLOGGING INDICATOR

For further technical informations and other options see page 185.



SPARE SEAL KIT

	NBR	FKM
FRD11	521.0045.2	521.0050.2
FRD21	521.0046.2	521.0051.2
FRD31	521.0047.2	521.0052.2
FRD41	521.0031.2	521.0019.2
FRD51	521.0048.2	521.0053.2
FRD61	521.0049.2	521.0054.2
FRD62	521.0049.2	521.0094.2

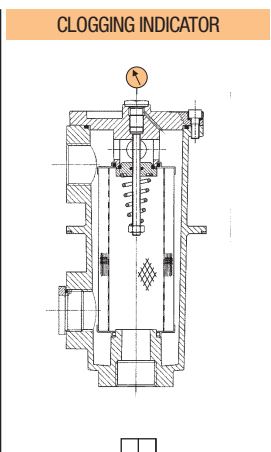
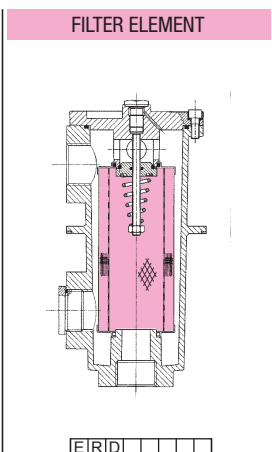
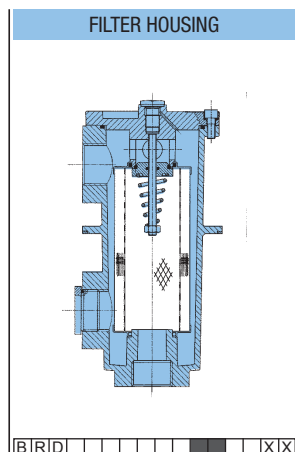
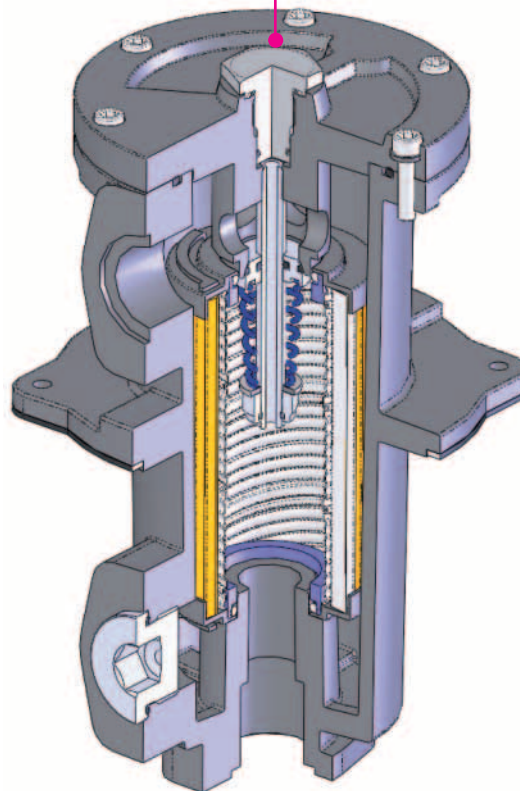

SPARE PARTS ELEMENTS
(For filling up see table "Ordering and option chart")

